

PRINCIPAL PARTICULARS

LENGTH O.A.	abt.179.90 m	COMPLEMENT	25P
LENGTH B.P.	171.50 m	SPEED	
BREADTH MLD.	28.40 m	SERVICE(d=10.00m, CSR(90%MCR) with 15% S.M.)	abt. 14.1 knots
DEPTH MLD.	14.10 m	TRIAL MAX.	abt.15.5 knots
DESIGNED DRAFT	10.00 m	CLASS NOTATION	
SCANTLING DRAFT	10.15 m	ABS: +A1(E) Bulk Carrier, CSR, SafeShip-CM,	
DEADWEIGHT (DESIGNED DRAFT)	abt. 31,800 M.T.	BC-A(holds.2,4 may be empty),	
DEADWEIGHT (SCANTLING DRAFT)	abt. 32,500 M.T.	UWILD, GRAB[20], ESP,	
GROSS TONNAGE (I.C.T.M.)	abt. 20,700	+AMS, +ACCU	
MAIN ENGINE			
MAN B&W 5S50MC (MARK6)	1 SET		
MCR	7150kW×127.0rpm		
CSR(90%MCR)	6435kW×122.6rpm		

ALTERATION				
DATE	REV. NO.	DESCRIPTION	DWN.	CHKD. APPD.

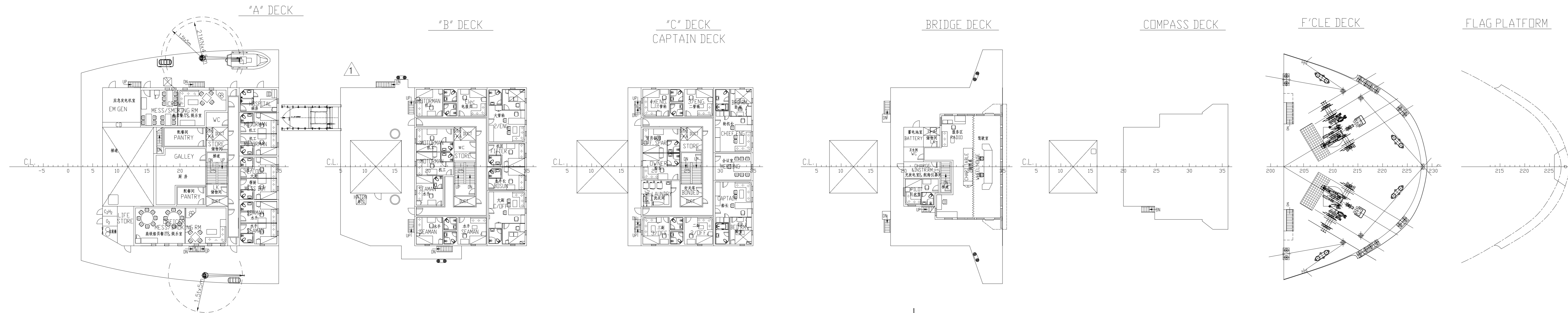
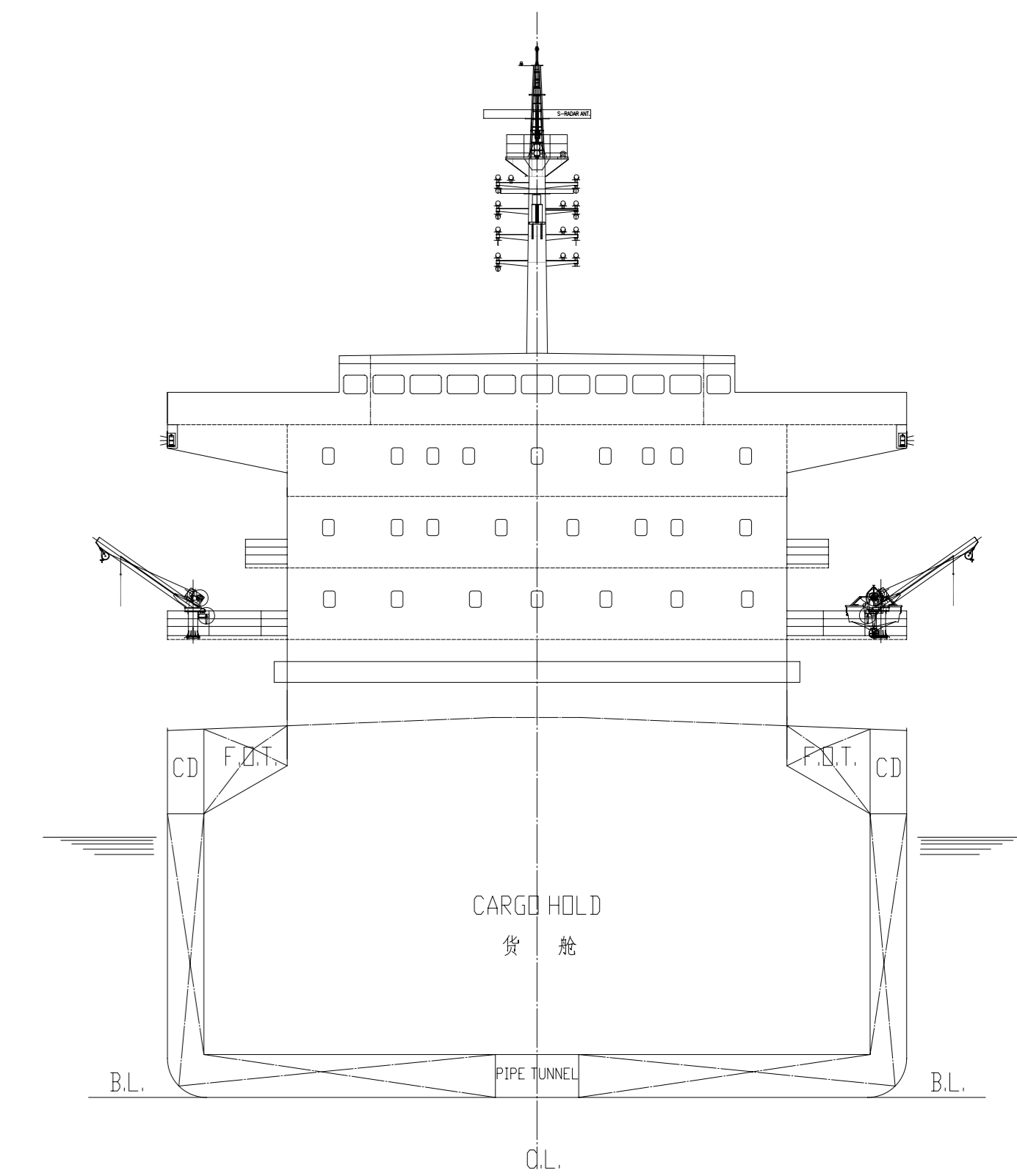
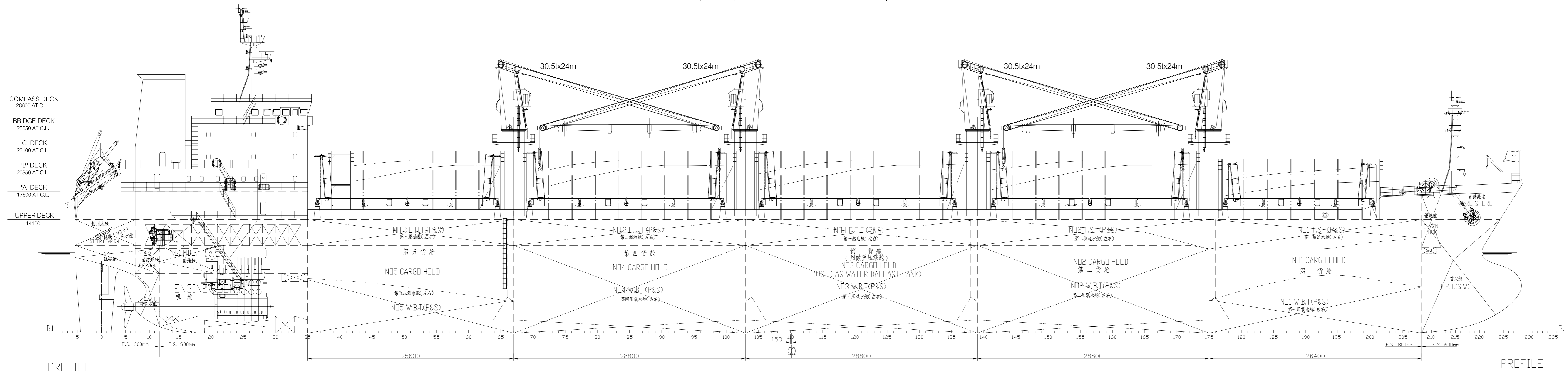

SHIP NAME: CMB EDOUARD
IMO No. : 9559690

BUILDER	Jiangsu LanBo Shipbuilding CO.,LTD	HULL NO.	VZJ432-0603
OWNER		CLASS	ABS
TITLE	32,500 DWT BULK CARRIER	FINISHED PLAN	
DESIGNED	张超	DWG. No.	JH433-050-02
CHECKED	张世明	SCALE	1:200
VERIFIED	杨永亮	WEIGHT	
APPROVED		PAGE	1/2
SHANGHAI BESTWAY MARINE ENGINEERING DESIGN CO.,LTD			
111 Cao Bao Road Shanghai, CHINA P.C:200233			
Tel:86-21-6436 5500 Fax:86-21-5448 7783 Email: luckway@mail.online.sh.cn			

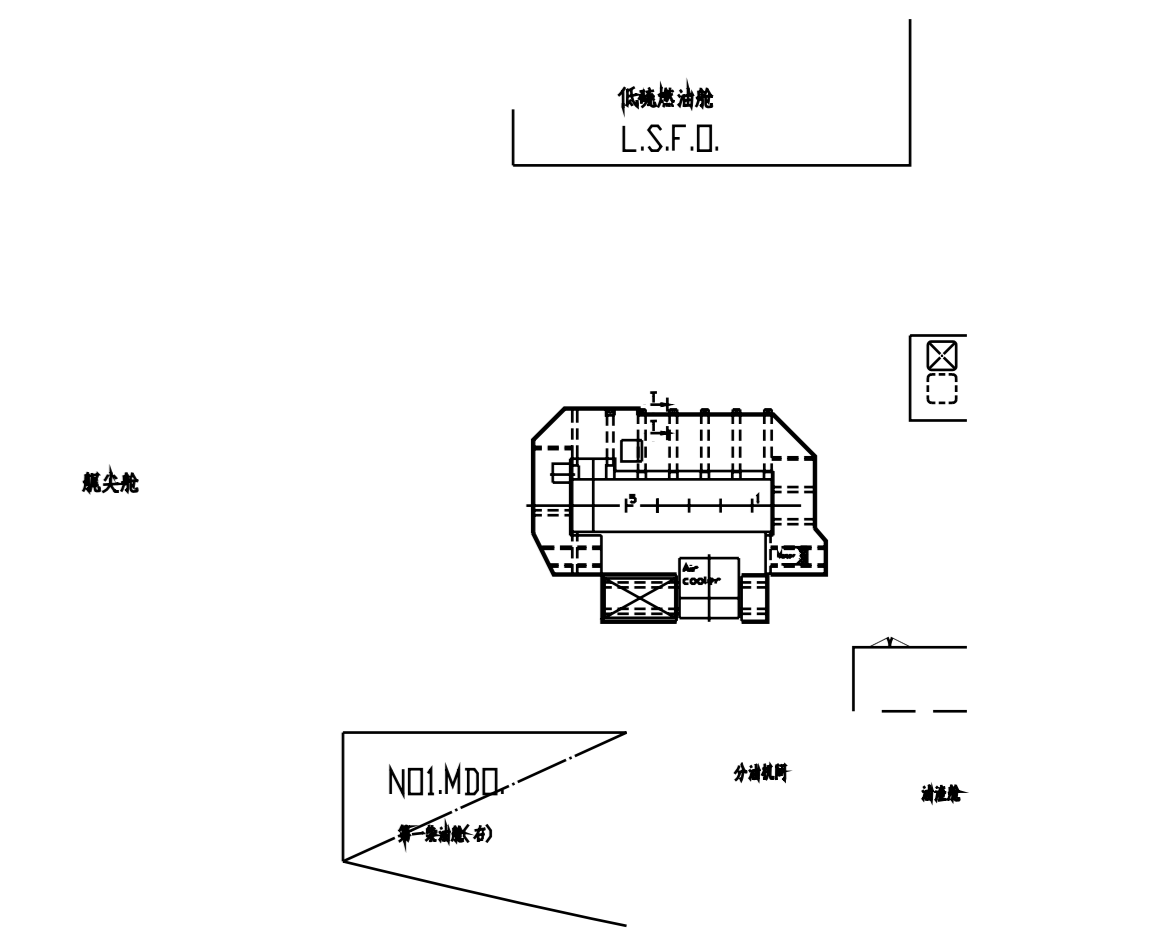
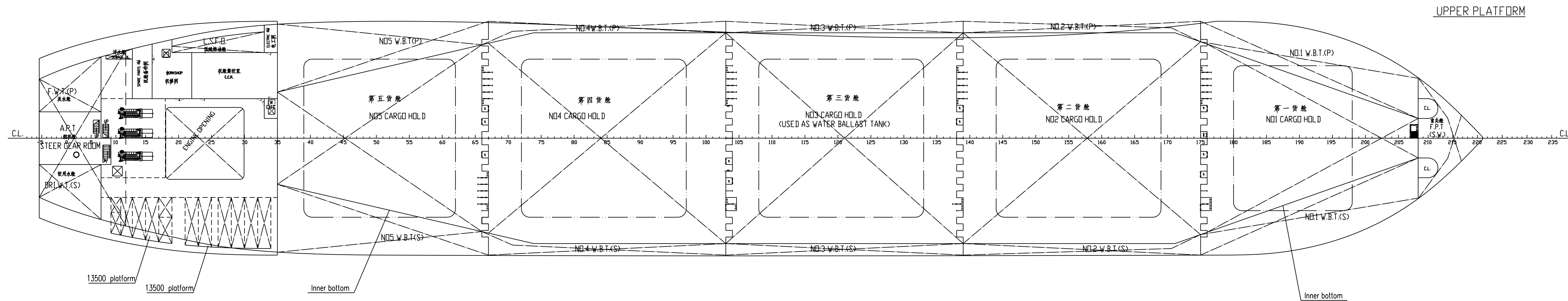
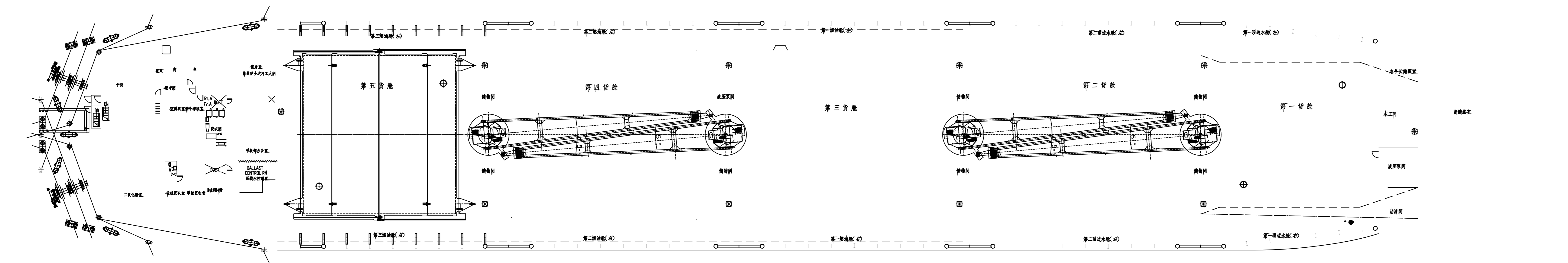

艏尖舱

UPPER PLATFORM

NO.1.MDD.

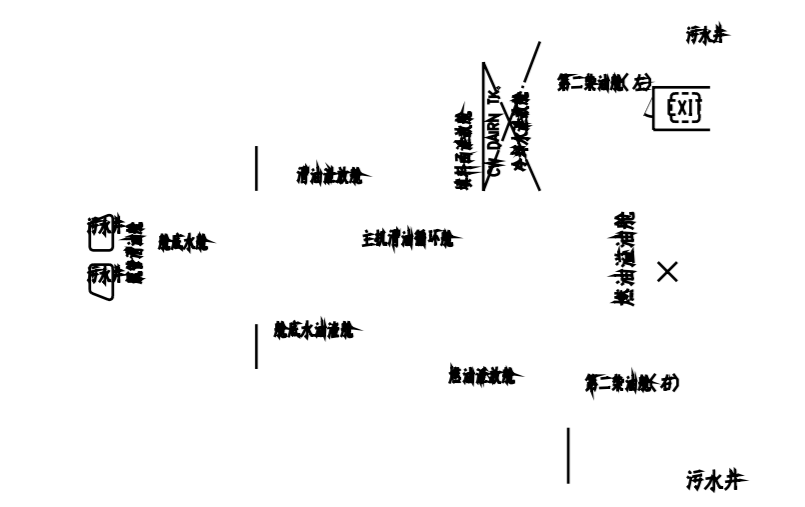

BUILDER	Jiangsu LanBo Shipbuilding CO.,LTD	HULL NO.	VZJ432-0603
OWNER		CLASS	ABS
TITLE	32,500 DWT BULK CARRIER	FINISHED PLAN	
DESIGNED	张世明	DWG. No.	JH433-050-02
CHECKED	张世明	SCALE	WEIGHT
VERIFIED	杨永光	PAGE	DATE
APPROVED		1/200	2/2
SHANGHAI BESTWAY MARINE ENGINEERING DESIGN CO.,LTD 111 Cao Bao Road Shanghai, CHINA P.C:200233 Tel:86-21-6436 5500 Fax:86-21-5448 7783 Email: luckway@mail.online.sh.cn			